

Peerless

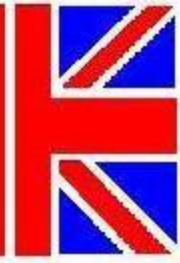

Planetary Mixers Planetary Mixer, 10 lt. - Table Model

ITEM # _____

MODEL # _____

NAME # _____

SIS # _____

AIA # _____



Planetary Mixers

Planetary Mixer, 10 lt. - Table Model

600230 (XBM10B)

10 lt planetary mixer, bowl detection device, with mechanical speed variation. Equipped with spiral hook, paddle and whisk. Equipped with highly resistant safety screen - BPA free

Short Form Specification

Item No. _____

Suitable for all kneading, blending and whipping operations. Body, feet and 10 litre capacity bowl in stainless steel. Powerful asynchronous motor (500 W) with mechanical speed variator (8 speed levels from 30 to 170 rpm). Water protected planetary system. Removable and dismantled solid safety screen activates the raising and lowering of the bowl. Water proof (IP55) and flat touch button control panel with 60 min. timer. Removable and dismantled solid safety screen - made of a bisphenol-A free (BPA) copolyester. Bowl detection device allows the mixer to switch on only when the bowl and the safety screen are properly installed and positioned together. A safety device will automatically stop the machine when the bowl is lowered. Adjustable feet for stability. Supplied with 3 tools: spiral hook, paddle and whisk.

Main Features

- Professional beater mixer that provides all the basic mixer functions: kneading of all sort of pastes, mixing of semi-liquid products, emulsions and various sauces.
- Delivered with:
 - Spiral Hook, Paddle, Wire Whisk and Mixing Bowl for 10 lt
- Mechanical speed variator.
- Removable safety screen activates the raising and lowering of the bowl.
- Maximum capacity (flour, with 60% of hydration) 3.5 kg, suitable for 10-50 meals per service.
- Safety device will automatically stop the machine when the bowl is lowered.
- Bowl detection device allows the mixer to switch on only when the bowl and the solid safety screen are properly installed and positioned together.

Construction

- Sturdy construction with mechanically welded strong metal frame.
- Compact design for table top installations.
- Body entirely in stainless steel.
- Asynchronous motor with high start-up torque.
- Power: 500 watts.
- Planetary movement based on self lubricating gears, eliminating any risk of leaks.
- 8 speeds, from 30 to 170 rpm, to be lever operated while the machine is working, according to the tool and the mixture hardness.
- Water protected planetary system (IP55 electrical controls, IP34 overall machine).
- AISI 302 stainless steel bowl - 10 lt. capacity.
- Waterproof touch button control panel with timer setting, display and pulse function.
- Adjustable feet to perfect stability.

Included Accessories

- 1 of Paddle 10 lt PNC 653267
- 1 of Spiral Hook 10 lt PNC 653268
- 1 of Whisk 10 lt PNC 653269
- 1 of Bowl 10 lt PNC 653276

Optional Accessories

- Paddle 10 lt PNC 653267
- Spiral Hook 10 lt PNC 653268
- Whisk 10 lt PNC 653269
- Bowl 10 lt PNC 653276

APPROVAL: _____



Planetary Mixers
Planetary Mixer, 10 lt. - Table Model

Peerless

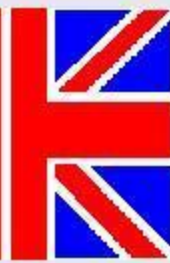

Planetary Mixers Planetary Mixer, 10 lt. - Table Model

Front

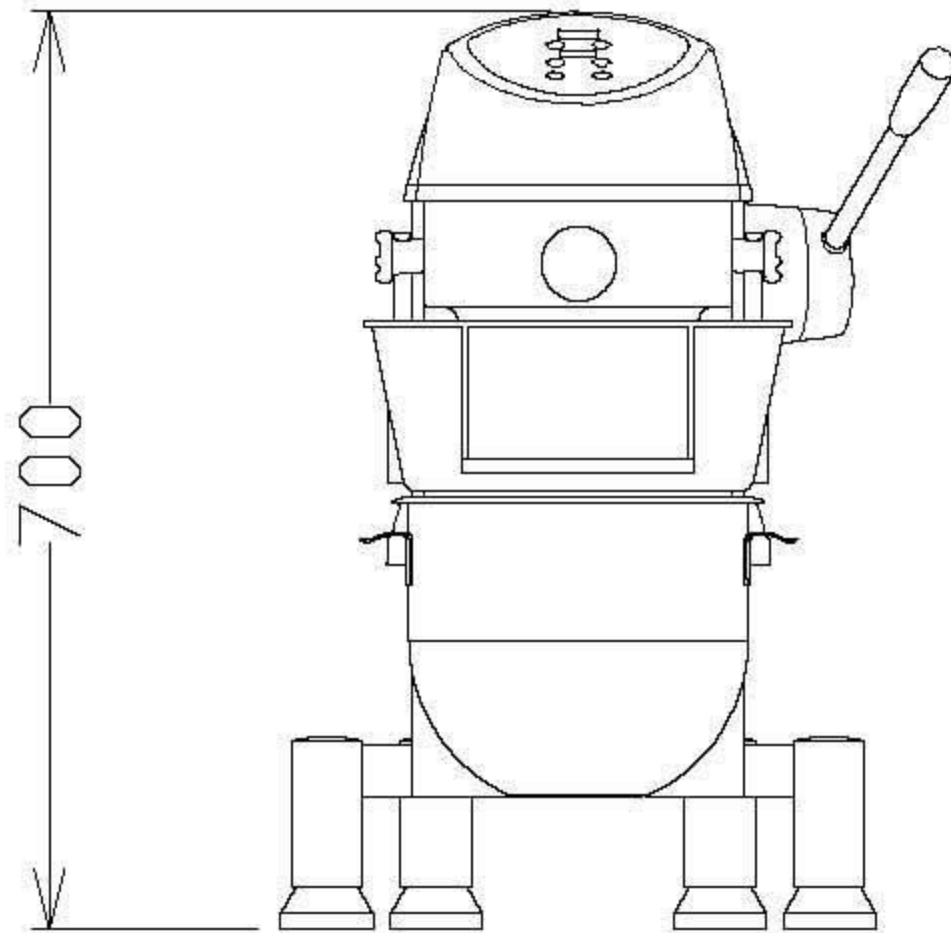

Top

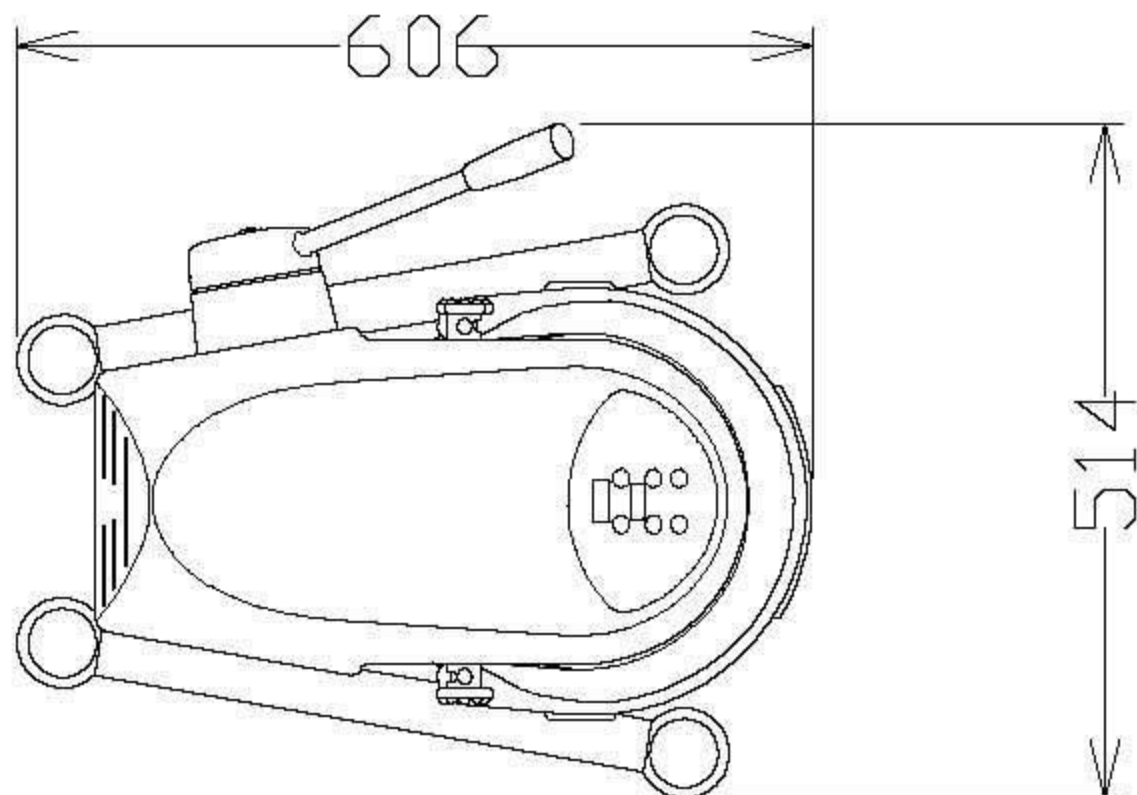

EI = Electrical connection

Side

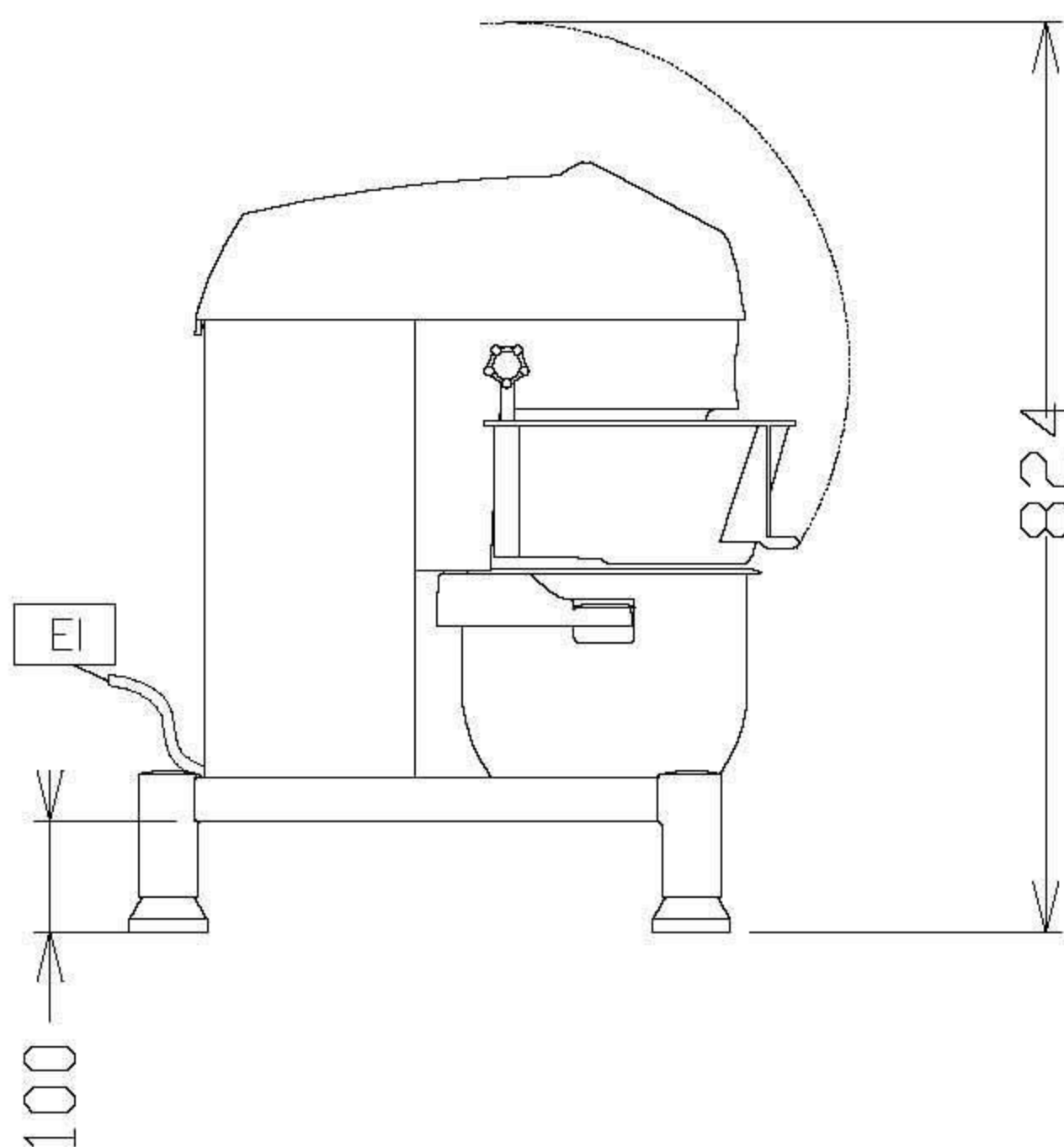

Electric

Supply voltage:

Supply voltage:	380-415 V/3 ph/50 Hz
600230 (XBM10B)	
Electrical power:	0.5 kW
Total Watts:	0.5 kW

Capacity:

Performance (up to):	3.5 - kg/Cycle
Capacity:	10 liter

Key Information:

External dimensions, Height:	700 mm
External dimensions, Width:	454 mm
External dimensions, Depth:	606 mm
Shipping weight:	57 kg
Cold water paste:	3.5 kg with Spiral hook
Egg whites:	18 with Whisk

Planetary Mixers
Planetary Mixer, 10 lt. - Table Model

The company reserves the right to make modifications to the products without prior notice. All information correct at time of printing.

2016.04.26

